



TEYME

ASM2-400 32" AIR BLAST SPRAYER

SPARE PARTS



SPRAYER N°:

MANUF. YEAR:

N	N_pieza	Denominación	Cant.	Proceso	Peso
1	0651010010	PASADOR ANILLA REDONDO Pera Ø9.5x44.5mm	2	Compra Std	0.06
2	2331010050	CONTERA INTERIOR C. 50x50	2	Compra Std	0.01
3	T180100002	KIT FICTICIO TORNILLERIA AT. SUSP. 4/600 - 2018	1	Compra Std	0.00
4	T180100004	KIT FICTICIO MANGUERAS AGUA AT. SUSP. 4/600 - 2018	1	Compra Std	0.00
5	2250280004	BULON Ø22 Ø28 Zn	2	Compra c/plano	0.09
6	2000300212	SOPORTE FILTRO ASPIRACION - Zn	1	Laser	0.20
7	2000600323	SOPORTE SUBDEPOSITO - PIN	1	Laser	1.02
8	2400050061	SUBCONJ. ASP. FILTRO/GRIFO 3V. 1 1/2" EQUIP. SUSP.	1	Montaje	1.48
9	2400050064	SUBCONJ. SUBDEPOSITO VIRGOLA-TC 40 L	1	Montaje	397.87
10	240034D009	SC.JTO DEPOSITO VERZELLESI 400 GRIS DTVS	1	Montaje	21.51
11	2400020002	BRIDA FIJACION CUAD. AB.50 M10x30 ZN	8	Soldadura	0.14
12	2400059017	BRIDA ANCLAJE DEPOSITO 4/600	2	Soldadura	0.17
13	2400059019	C.JTO. GUJA ASM - 765 - PIN	2	Soldadura	5.83
14	2400059190	CONJUNTO SOLDADO - PIN	1	Soldadura	59.07

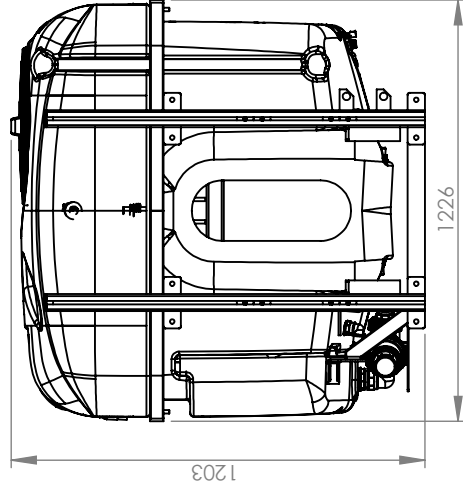
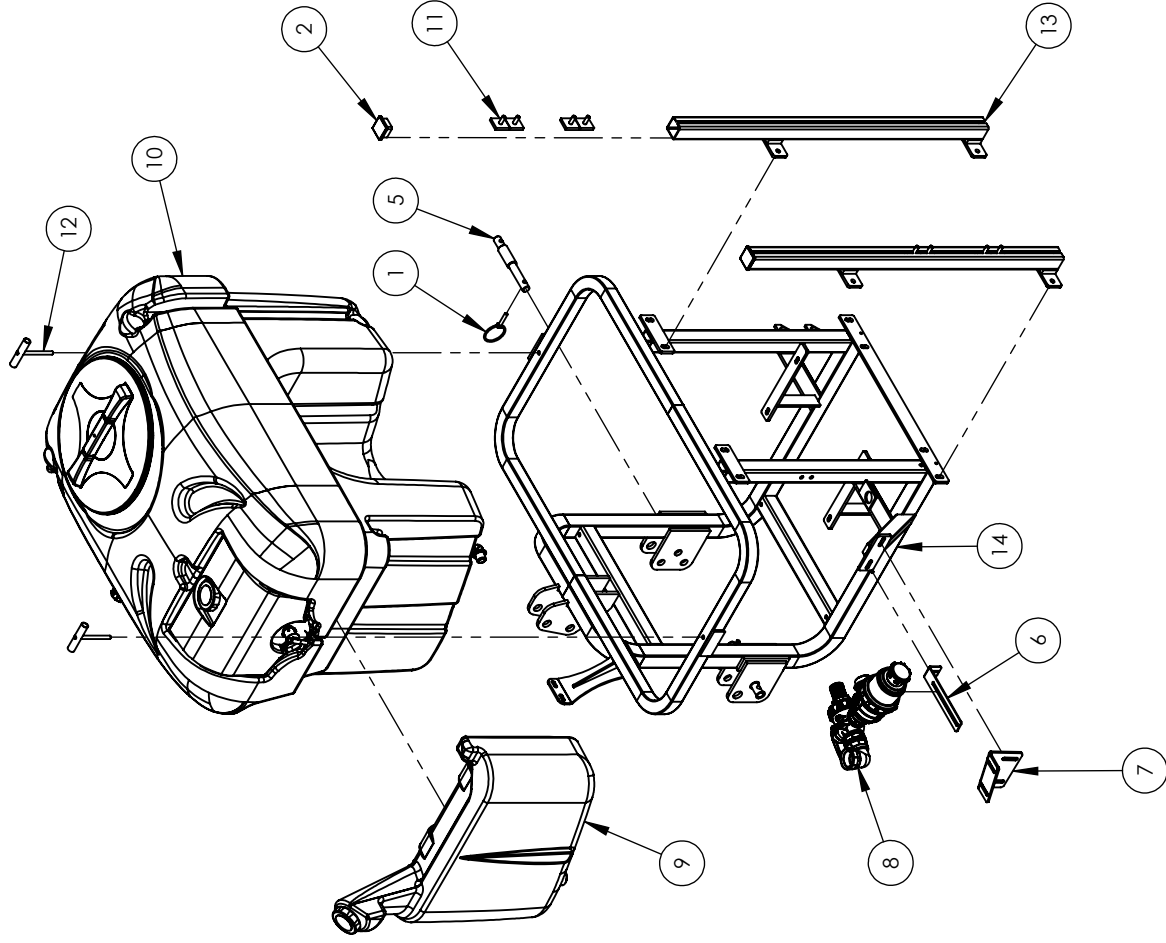

Denominación:	EQUIPO BASE SUSPENDIDO ASMDTVS 400	Nº hoja:	1/1
Materia:	400	Peso:	494.59kg
Dibujado:	15/11/2018	M. Amorós	
Modificado:		Tipo acabado:	----
		Interviene en:	
 <p>Pol. Ind. SAU 3, C/ Girona - 25131 TORRESERONA (Lleida) - SPAIN Telf. 973 750 033 - Fax. 973 751 581 www.teyme.es - e-mail: comercial@teyme.es</p>		Nº Plano	T180104000
		Proceso	Montaje
		ESCALA	1:22
		Versión	00

Este plano es propiedad de TEYME Tecnología Agrícola, S.L. Prohibida su reproducción y cesión a terceros.

Suavizar aristas
 Cotas sin tolerancia según ISO2768-1 en grado m (medio)

105gal ASM & CANNON FRAME

Nº	CODE	DESCRIPTION
1	0651010010	Ø9.5x44.5mm SAFETY CATCH
2	2331010050	C.50x50 CAP
3	T180100002	105/158GAL FRAME SCREWS KIT
4	T180100004	105/158GAL HOSES KIT
5	2250280004	Ø22 Ø28 Zn BOLT
6	2000300212	SUCTION FILTER HOLDER
7	2000600323	CLEAN WATER TANK HOLDER
8	2400050061	1 1/2" SUCTION FILTER KIT
9	2400050064	11GAL CLEAN WATER TANK KIT
10	240034D009	105GAL TANK KIT
11	2400020002	AB.50 M10x30 ZN CLAMP
12	2400059017	FIXING TANK CLAMP
13	2400059019	FAN HOLDER KIT
14	2400059190	CLEAN WATER TANK HOLDER 2

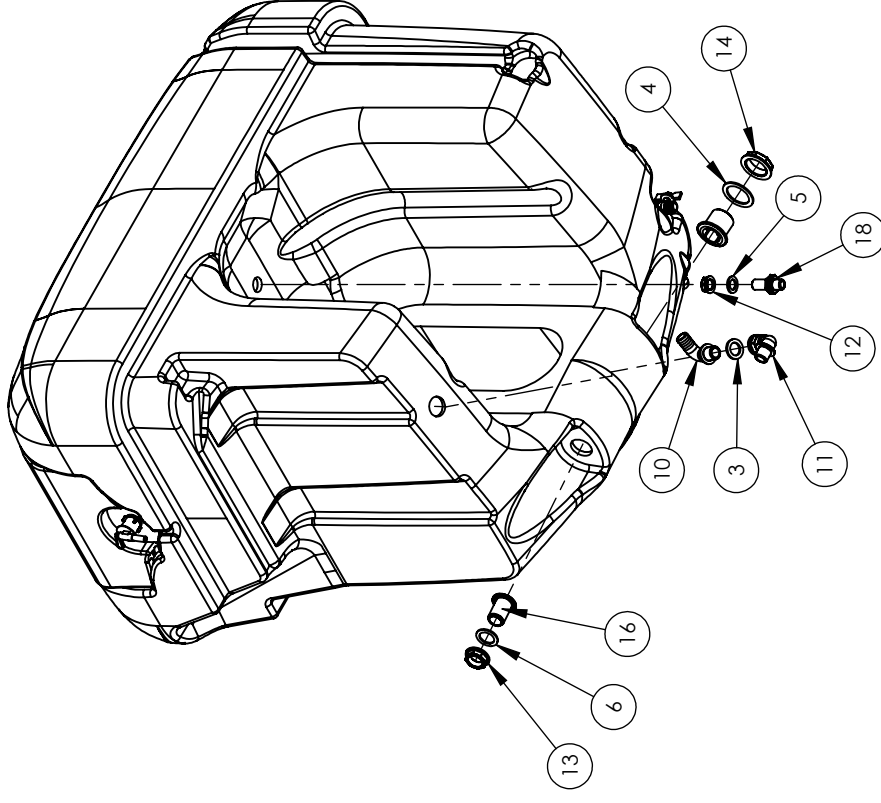
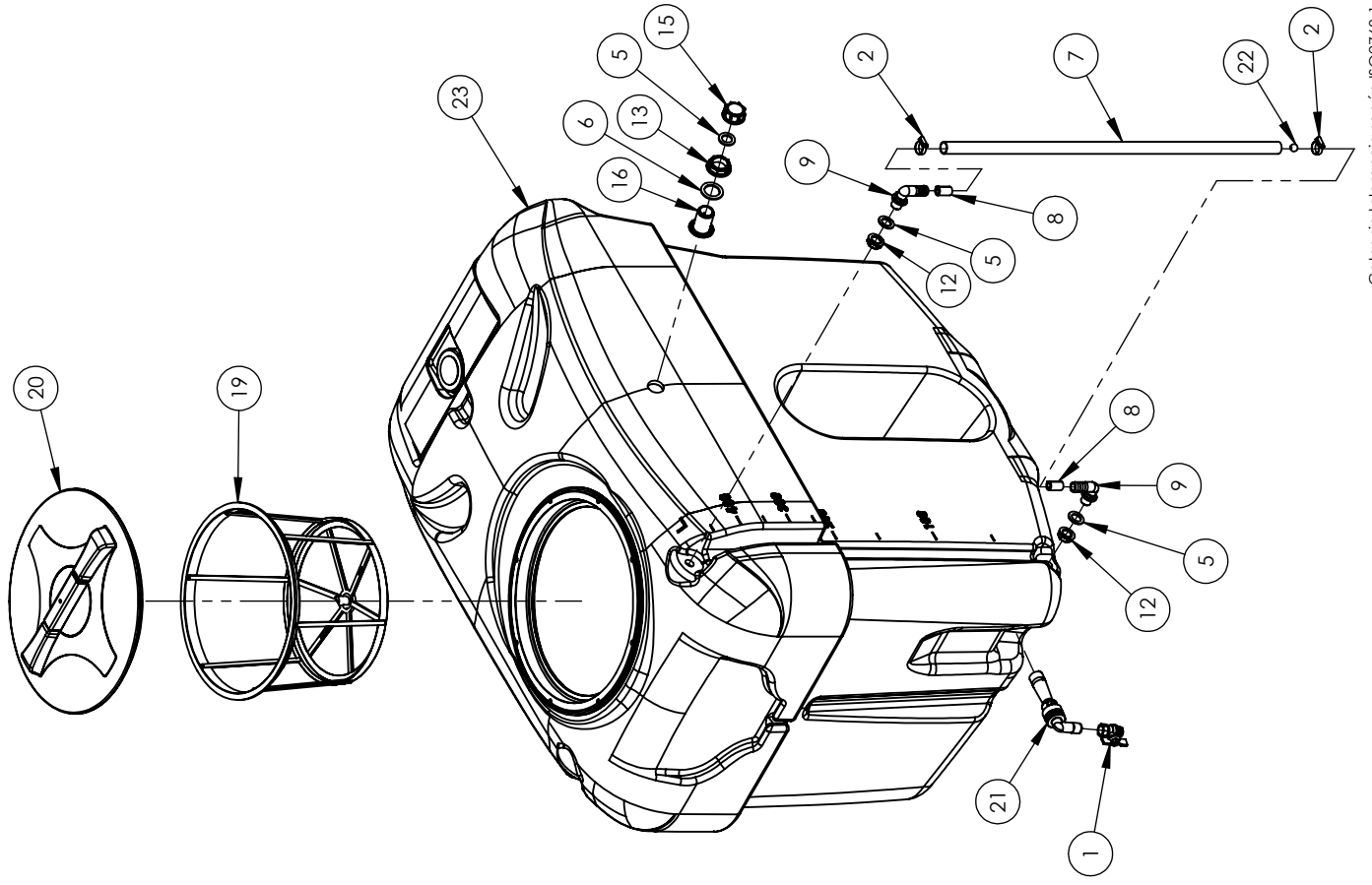

Denominación: SCJTO DEPOSITO VERZELLESI 400 GRIS DTVS		Nº hoja: 1/2
Material: 400Lts		Peso: 21,91kg
Dibujado: 16/11/2018	M. Amorós	Tipo acabado: -----
Modificado:		Interviene en:
		
Pol. Ind. SAU 3, C/ Girona - 25131 TORRESERONA (Lleida) - SPAIN Telf. 973 750 033 - Fax. 973 751 581 www.teyme.es - e-mail: comercial@teyme.es		N° Plano 240034D009 Versión 00
		Proceso Montaje
		ESCALA 1:15

Cotas sin tolerancia según ISO2768-1 en grado m (medio)
 Suavizar aristas

Este plano es propiedad de TEYME Tecnología Agrícola, S.L. Prohibida su reproducción y cesión a terceros.

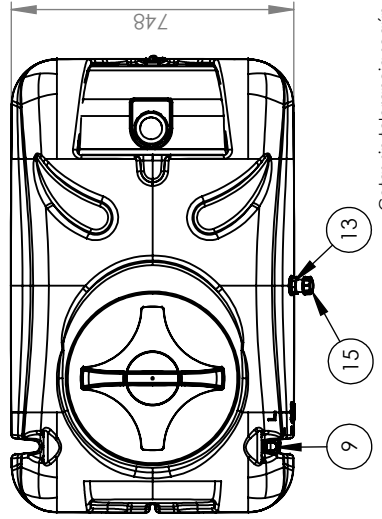
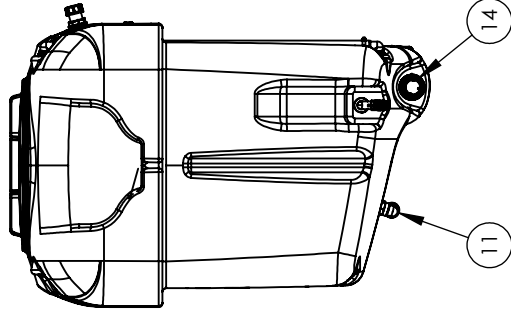
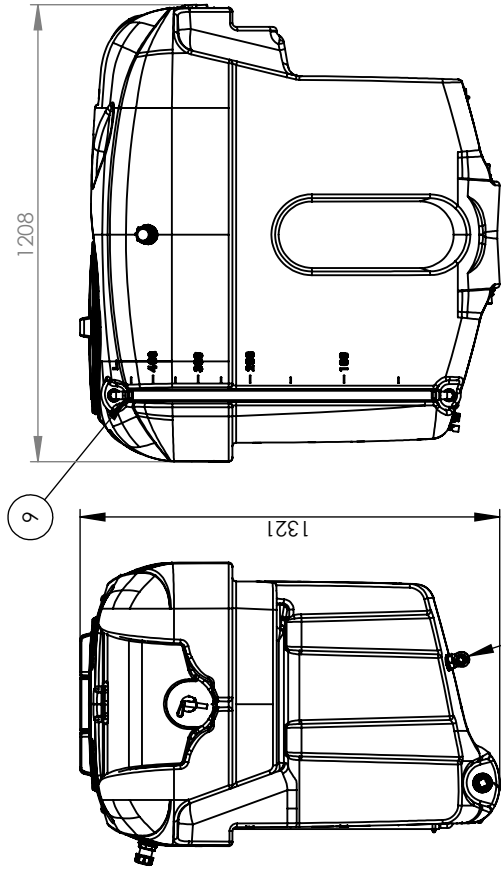
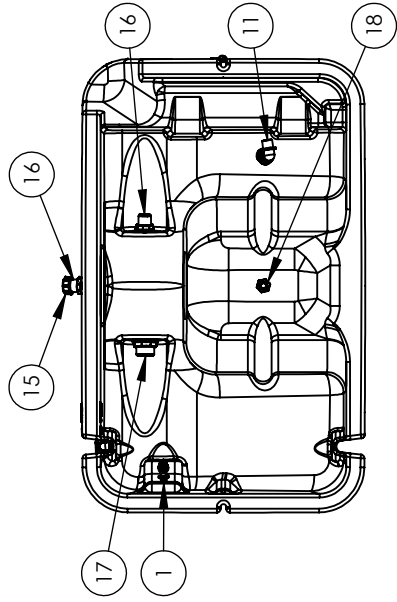

N	N_pieza	Denominación	Cant.	Proceso	Peso
1	0170010002	VALV. ESFERA M-H 1/2 T3000-MAR	1	Compra Std	0.15
2	0600010027	ABRAZADERA SIN-FIN 16-27	2	Compra Std	0.01
3	0790020020	JUNTA PLANA GOMA P/R 3/4 40x26x2	2	Compra Std	0.00
4	0790020050	JUNTA PLANA GOMA P/R 1 1/2"	1	Compra Std	0.00
5	0790060010	JUNTA PLANA SILICONA 1/2	4	Compra Std	0.01
6	0790060020	JUNTA PLANA NBR	2	Compra Std	0.00
7	1050010005	MANGUERA Ø20 SPRINGVIN ATOX. (€/mt.)	1	Compra Std	0.25
8	1050800007	MANGUERA OROTAWA 80 Bar Ø10mm.	2	Compra Std	0.01
9	A001132220	RACOR CURVO P.P. M 1/2"-Ø20	2	Compra Std	0.02
10	A001132325	RACOR CURVO P.P. M3 /4"-Ø25	1	Compra Std	0.03
11	A001262033	RACOR CURVO P.P. 90º M-H 3/4"	1	Compra Std	0.03
12	A002052020	TUERCA P.P. 1/2"	3	Compra Std	0.04
13	A002052040	TUERCA P.P. 1" 50x15.5	2	Compra Std	0.01
14	A002052060	TUERCA P.P. 1 1/2" 67x15	1	Compra Std	0.02
15	A002102040	TAPON HEMBRA P.P. 1"	1	Compra Std	0.01
16	A00220040	RACOR DESAGUE G1" 50mm	2	Compra Std	0.02
17	A00220060	RACOR DESAGUE P.P. 1 1/2"	1	Compra Std	0.04
18	A002502021	UNION PASAPARED P.P. M-M 1/2" 38x18	1	Compra Std	0.02
19	A00300130	FILTRO FORMA DE SACO 18 MESH Ø400 380x275mm LARGO	1	Compra Std	1.39
20	A003522060	TAPA ROSC. SMOOTH-LINE 2 CON RESP LABER Ø455	1	Compra Std	1.07
21	A00502010	AGITADOR HIDRAULICO CURVO PEQUEÑO Ø1.2mm INOX	1	Compra Std	0.06
22	A00509219010	BOLA INDICADOR NIVEL D.15.5 NARANJA	1	Compra Std	0.00
23	VZL1V7043QO1	DEPOSITO SUS.POL.SERIE VIRGOLA-TC 400 L 3 PS B1	1	Compra Std	0.00

Denominación: SCJTO DEPOSITO VERZELLESI 400 GRIS DTVS

Nº hoja: 2/2

Materia: 400Lts

Peso: 21.91kg

Dibujado 16/11/2018

Tipo acabado: ----

Modificado

Interviene en:



Pol. Ind. SAU 3, C/ Gitona - 25131 TORRESERONA (Lleida) - SPAIN
 Telf. 973 750 033 - Fax. 973 751 581
 www.teyme.es - e-mail: comercial@teyme.es

Nº Plano

240034D009

ESCALA

1:20

Proceso

Versión

Montaje



Suavizar aristas

Cotas sin tolerancia según ISO2768-1 en grado m (medio)

Este plano es propiedad de TEYME Tecnología Agrícola, S.L. Prohibida su reproducción y cesión a terceros.

105gal ASM & CANNON TANK

Nº	CODE	DESCRIPTION
1	0170010002	M-H 1/2" T3000 BALL VALVE
2	0600010027	16-27 ENDLESS CLAMP
3	0790020020	3/4" 40x26x2 FLAT GASKET
4	0790020050	1 1/2" FLAT GASKET
5	0790060010	1/2" FLAT GASKET
6	0790060020	1" FLAT GASKET
7	1050010005	D.20 SPRINGVIN ATOX. HOSE
8	1050800007	OROTAWA 80 Bar D.10 HOSE
9	A001132220	M 1/2"-D.20 ANGLED HOSE FITTING
10	A001132325	P.P. M3/4" Ø25 ANGLED HOSE FITTING
11	A001262033	P.P. 90º M-H 3/4" ANGLED HOSE FITTING
12	A002052020	P.P. 1/2" FLY NUT
13	A002052040	P.P. 1" 50x15,5 FLY NUT
14	A002052060	P.P. 1 1/2" 67x15 FLY NUT
15	A002102040	P.P. 1" BLANKING CAP
16	A00220040	P.P. 1" DRAIN HOSE FITTING
17	A00220060	1 1/2" DRAIN HOSE FITTING
18	A002502021	P.P. M-M 1/2" 38x18 BULKHEAD UNION
19	A00300130	18 MESH Ø400 380x275mm TANK FILLING FILTER
20	A003522060	SMOOTH-LINE 2 Ø455 THREADED LID
21	A00502010	Ø1.2mm ANGLED HYDRAULIC STIRRER
22	A00509219010	D.15,5 ORANGE LEVEL BALL
23	VZL1VT043QO1	105GAL POLYETHYLENE TANK

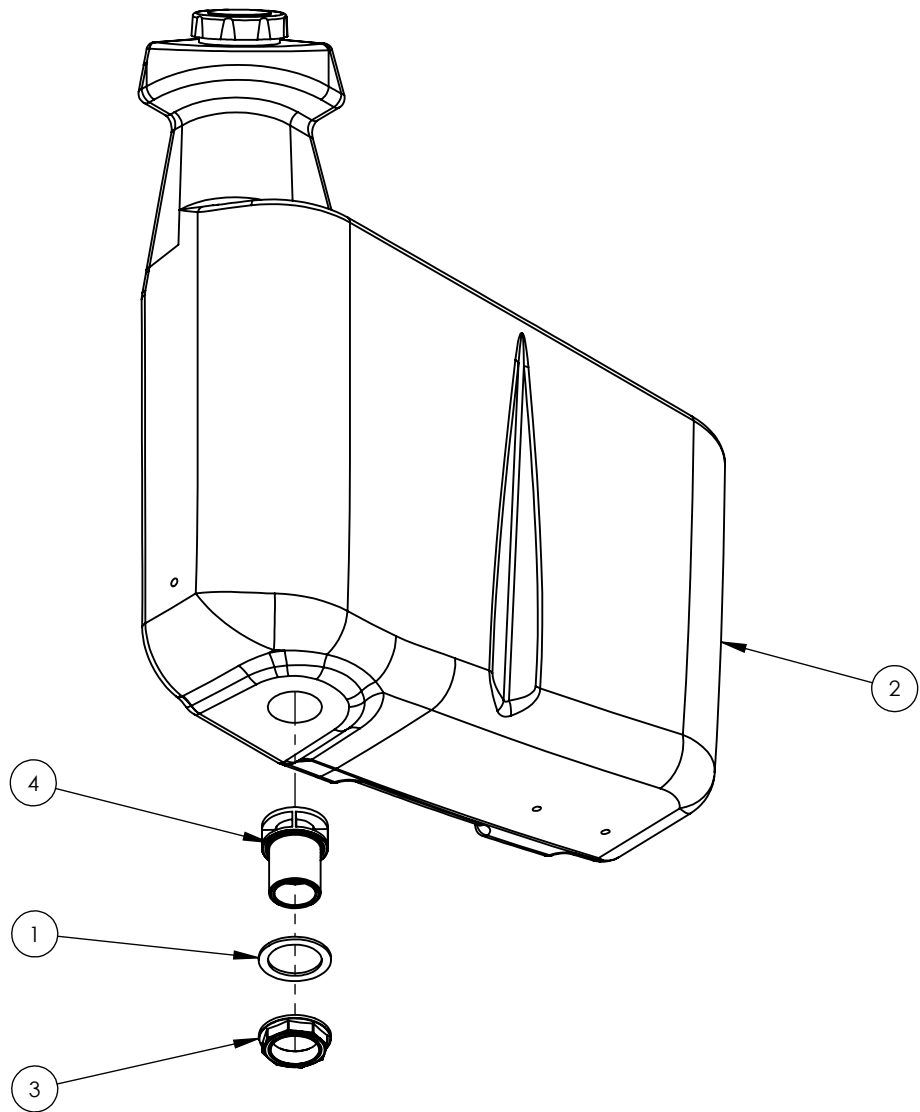



N	N_pieza	Denominación	Cant.	Proceso	Peso
1	0790020050	JUNTA PLANA GOMA P/R 1 1/2"	1	Compra Std	0.00
2	1100020001	SUBDEPOSITO VIRGOLA-TC 40 L. AZUL OSCURO	1	Compra Std	397.75
3	A002052060	TUERCA P.P. 1 1/2" 67x15	1	Compra Std	0.02
4	A005042106M	TOMA AGUA P.P. ANTIRREMOLINO M 1 1/2" Ø100	1	Mecanizado	0.06

Denominación: SUBCONJ. SUBDEPOSITO VIRGOLA-TC 40 L

Nº hoja: 1/1

Material: 40Lts

Peso: 397.87kg

Dibujado	15/11/2018	M. Amorós	Tipo acabado:	----
Modificado			Interviene en:	HSBS 400/600
 Pol. Ind. SAU 3, C/ Girona - 25131 TORRESERONA (Leida) - SPAIN Telf. 973 750 033 - Fax. 973 751 581 www.teyme.es - e-mail: comercial@teyme.es			Nº Plano	2400050064
			Proceso	Montaje
			Versión	00
			ESCALA	1:7
				

Suavizar aristas

Cotas sin tolerancia según ISO2768-1 en grado m (medio)

11gal ASM & CANNON CLEAN WATER TANK

Nº	CODE	DESCRIPTION
1	0790020050	1 1/2" FLAT GASKET
2	1100020001	11GAL CLEAN WATER TANK
3	A002052060	P.P. 1 1/2" 67x15 FLY NUT
4	A005042106M	Ø90 M 1 1/2" ANTI-VORTEX OUTLET

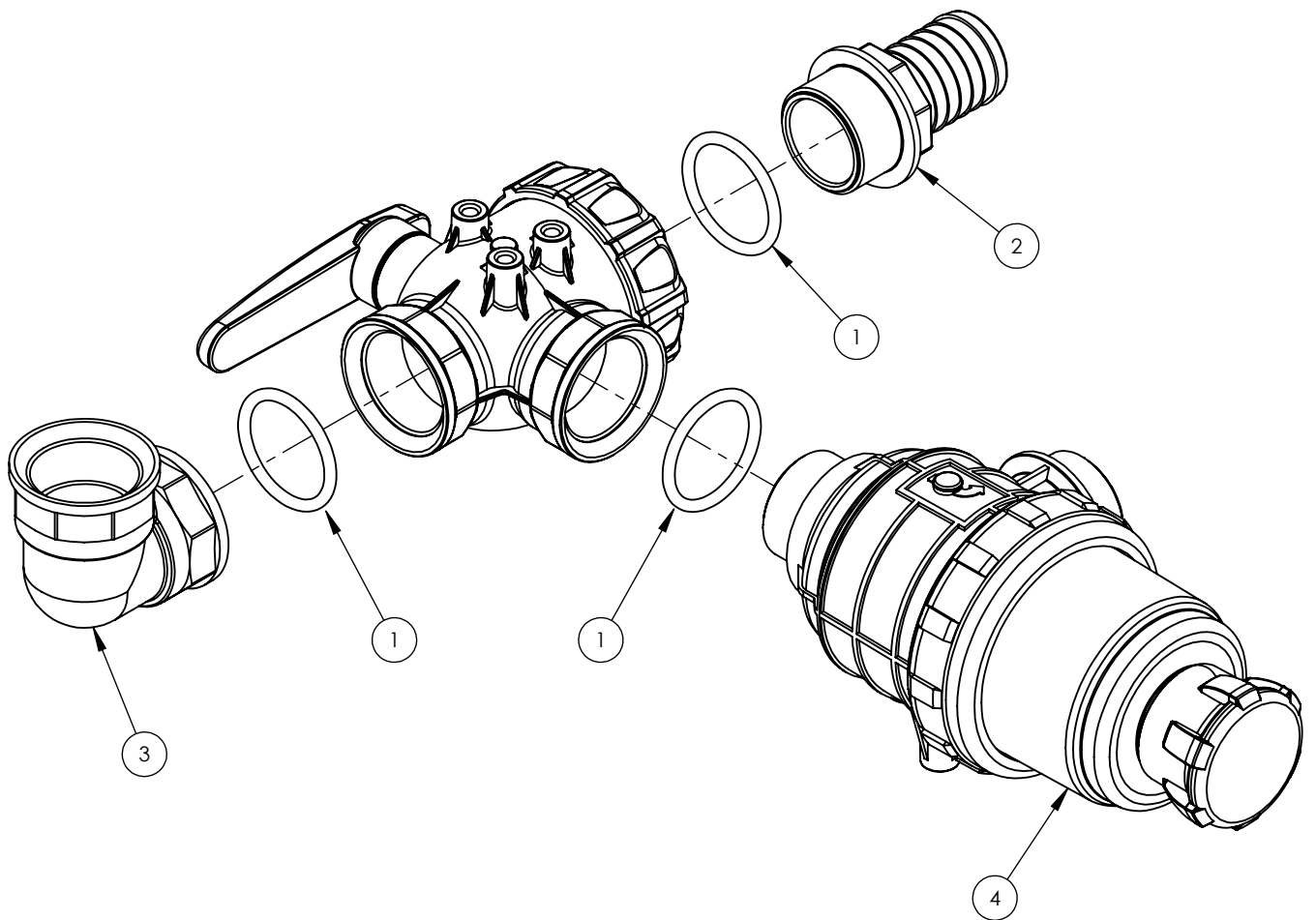

N	N_pieza	Denominación	Cantf.	Proceso	Peso
1	0790010013	JUNTA TORICA Ø INT.45x5	3	Compra Std	0.02
2	A001032640	RACOR RECTO P.P. M 1 1/2" Ø40	1	Compra Std	0.45
3	A001202066	RACOR CURVO P.P. 90° H-H 1 1/2"	1	Compra Std	0.76
4	A003142462	FILTRO ASP 314 C/VALV M 1 1/2" R24mm ROJO 32M	1	Compra Std	0.00
5	A0045521116	VALVULA DE BOLA H-1 1/2 3 VIAS	1	Compra Std	0.20

Denominación: SUBCONJ. ASP. FILTRO/GRIFO 3V. 1 1/2" EQUIP.SUSP.

Nº hoja: 1/1

Material: 3V. 1 1/2"

Peso: 1.48kg

Dibujado	14/11/2018	M. Amorós	Tipo acabado:	----
Modificado			Interviene en:	ASM/DTVS 4/600
 Pol. Ind. SAU 3, C/ Girona - 25131 TORRESERONA (Leida) - SPAIN Telf. 973 750 033 - Fax. 973 751 581 www.teyme.es - e-mail: comercial@teyme.es			Nº Plano	2400050061
			Proceso	Montaje
			Versión	00
				ESCALA 1:3
				⊕ ⊖

Suavizar aristas

Cotas sin tolerancia según ISO2768-1 en grado m (medio)

1 1/2" SUCTION FILTER KIT

Nº	CODE	DESCRIPTION
1	0790010013	ØINT.45x5 GASKET
2	A001032640	P.P. M 1 1/2" Ø40 STRAIGHT HOSE FITTING
3	A001202066	P.P. 90º H-H 1 1/2" ANGLED HOSE FITTING
4	A003142462	314 C/VALV M 1 1/2" SUCTION FILTER
5	A0045521116	H-1 1/2 3-WAY BALL VALVE

N	N_pieza	Denominación	Cant.	Proceso	Peso
1	A003452010.B10	RACOR LATON M 3/4" C/ACOPLAMIENTO P/HORQUILLA	2	Compra Std	0.11
2	A003452113.910	FILTRO ALTA PRES 3452 CARTUCHO AZUL DE 725 PSI	1	Compra Std	0.00
3	2400041640	CJTO. MANDO DISTANCIA COMET	1	Montaje	1.65
4	2400048076	CJTO. MANGUERAS MANDO DISTANCIA (COMET) POLIETILE	1	Montaje	7.57

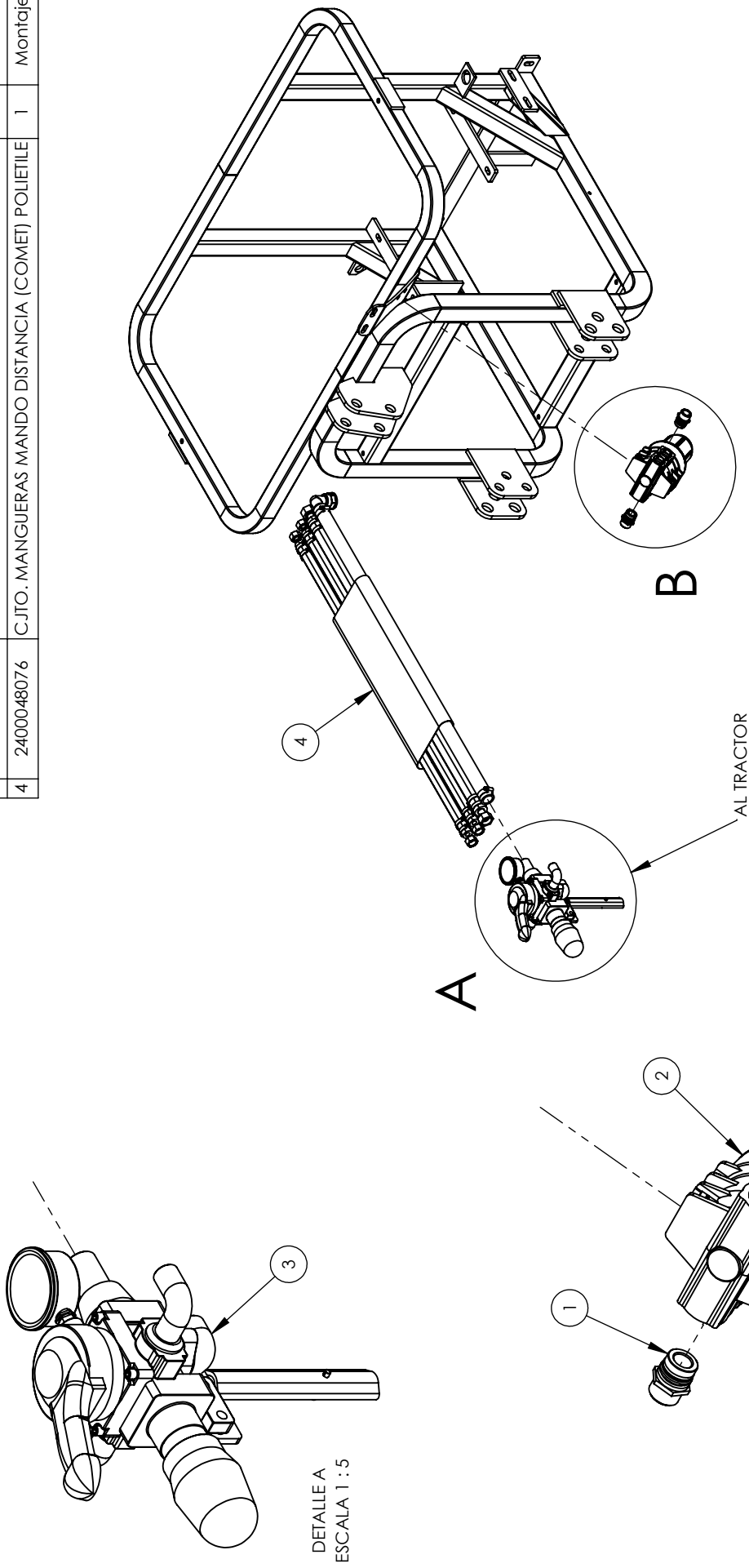

Denominación: SCJTO MANDO MANUAL LATON		Nº hoja: 1/1
Material:		Peso: 68,45kg
Dibujado	26/11/2018	M. Amorós
Modificado		
Tipo acabado: -----		
Interviene en:		
ATOMIZADORES SUSPENDIDOS		
Nº Plano	T060000001	ESCALA 1:15
Proceso	Montaje	Versión 00
 TEYME Tecnología Agrícola, s.i. Pol. Ind. SAU 3, C/ Gitona - 25131 TORRESERONA (Lleida) - SPAIN Telf. 973 750 033 - Fax. 973 751 581 www.teyme.es - e-mail: comercial@teyme.es		

DETALLE B
ESCALA 1 : 5

DETALLE A
ESCALA 1 : 5

Suavizar aristas
Cotas sin tolerancia según ISO2768-1 en grado m (medio)

Este plano es propiedad de TEYME Tecnología Agrícola, S.L. Prohibida su reproducción y cesión a terceros.

GRH MECHANICAL CONTROL

Nº	CODE	DESCRIPTION
1	A003452010B10	3/4" BRASS HOSE FITTING
2	A003452113910	HIGH PRESSURE FILTER 3452 MODEL
3	2400041640	GRH MECHANICAL CONTROL KIT
4	2400048076	GRH MECHANICAL CONTROL HOSES KIT

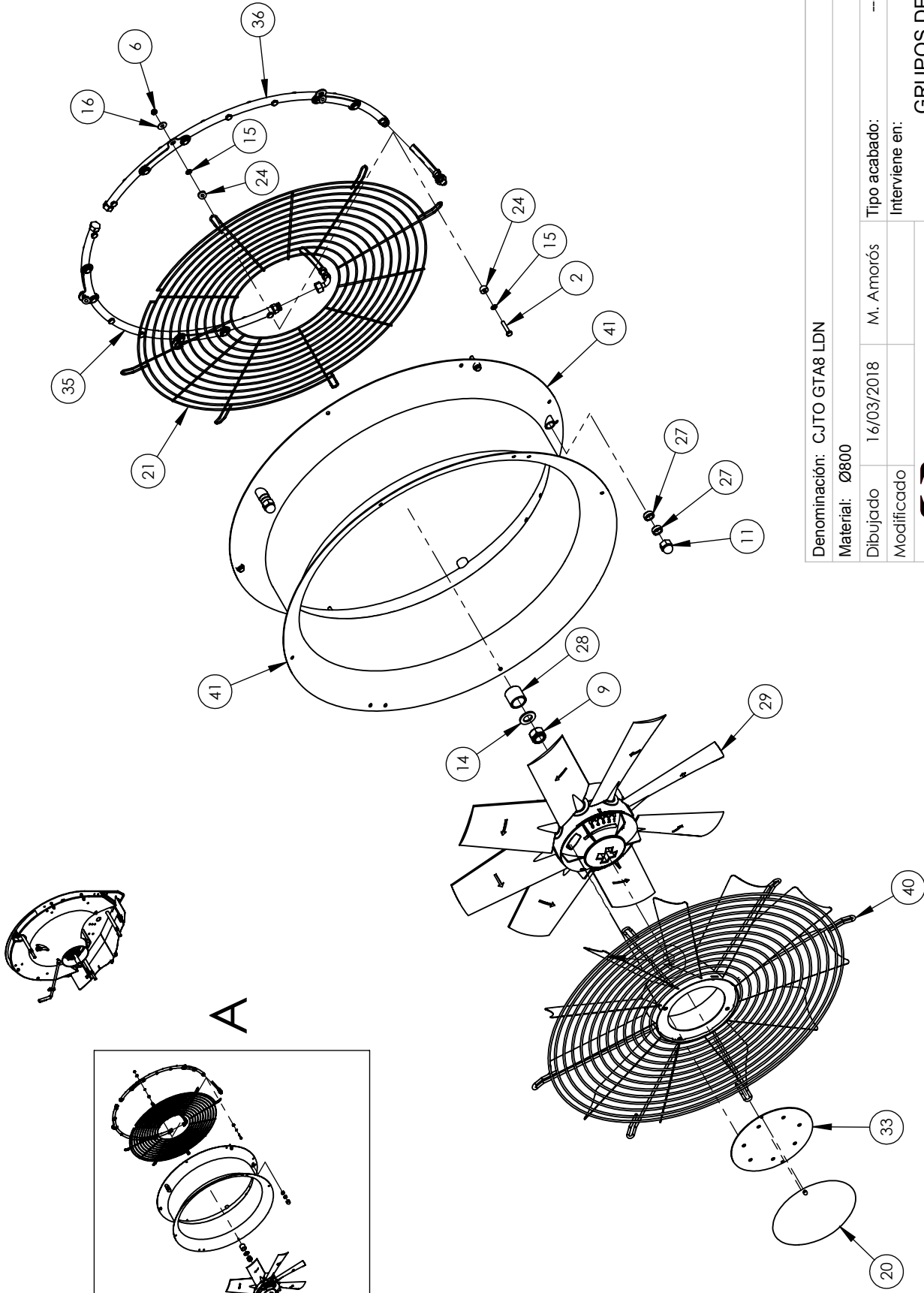

DETALLE A
ESCALA 1 : 15

Denominación: CJTO GTA8 LDN		Nº hoja: 1/3
Material: Ø800		Peso: 90,84kg
Dibujado: 16/03/2018	M. Amorós	Tipo acabado: -----
Modificado:		Interviene en:
GRUPOS DE AIRE		
Nº Plano		ESCALA
T020000004		1:50
Proceso	Versión	
Montaje	00	
 TEYME Tecnología Agrícola, s.i. Pol. Ind. SAU 3, C/ Gitana - 25131 TORRESERONA (Lleida) - SPAIN Telf. 973 750 033 - Fax. 973 751 581 www.teyme.es - e-mail: comercial@teyme.es		

Cotas sin tolerancia según ISO2768-1 en grado m (medio)
 Suavizar aristas

Este plano es propiedad de TEYME Tecnología Agrícola, S.L. Prohibida su reproducción y cesión a terceros.

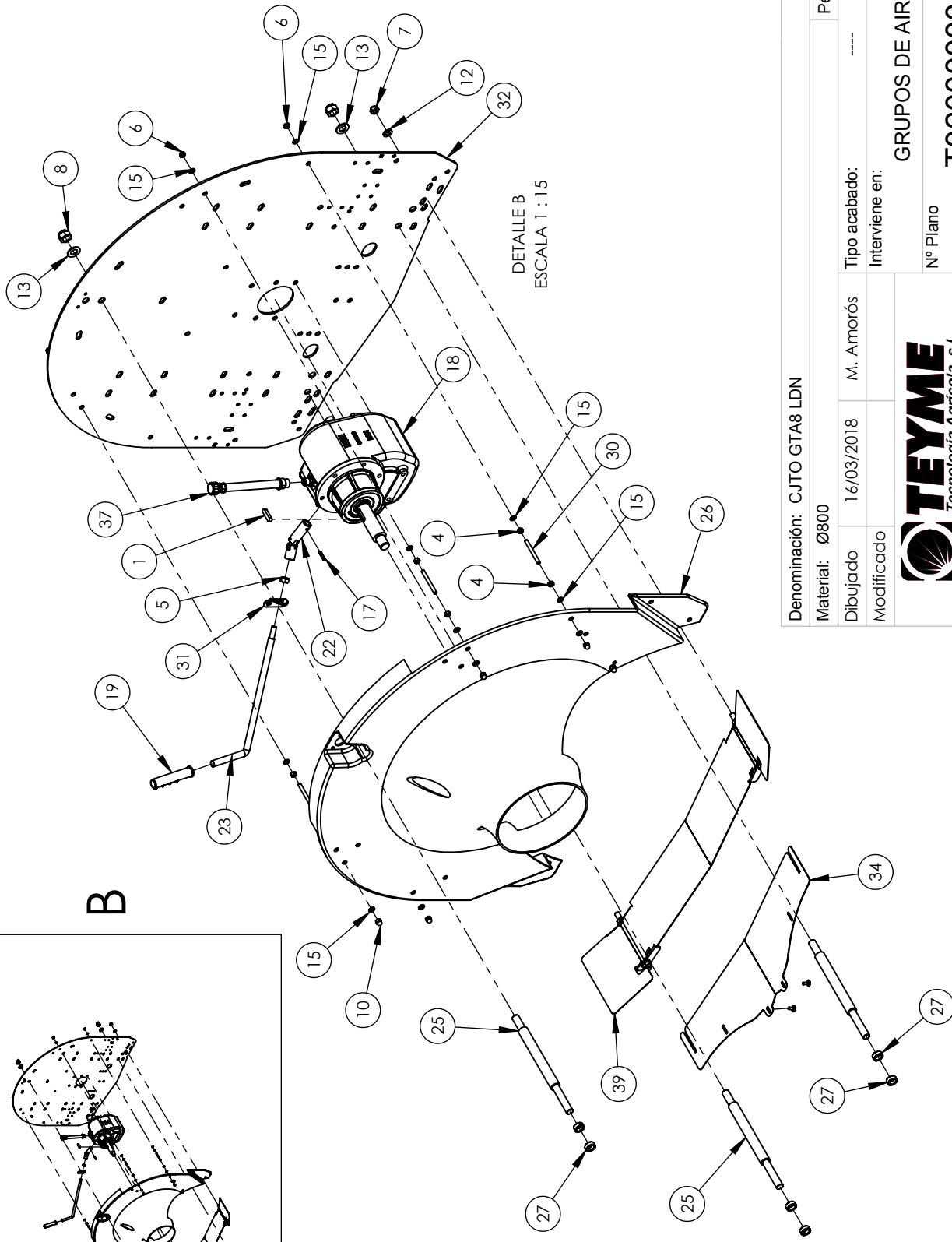
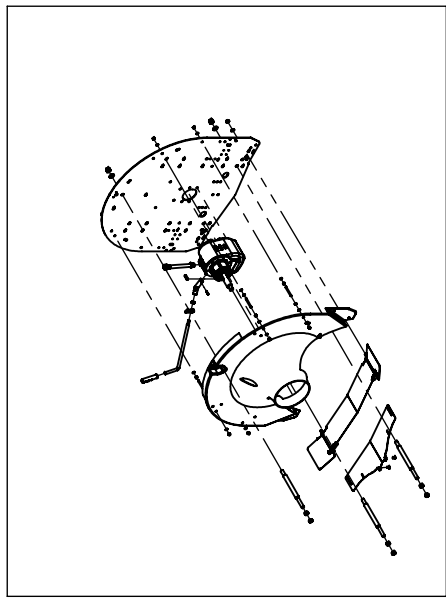

DETALLE B
ESCALA 1 : 15

Denominación: CJTO GTA8 LDN	Nº hoja: 2/3
Material: Ø800	Peso: 90,84kg
Dibujado: 16/03/2018	M. Amorós
Modificado:	
Tipo acabado: -----	
Interviene en:	
GRUPOS DE AIRE	
Nº Plano	ESCALA
T020000004	1:50
Proceso	Versión
Montaje	00



Pol. Ind. SAU 3, C/ Girona - 25131 TORRESERONA (Lleida) - SPAIN
 Telf: 973 750 033 - Fax: 973 751 581
 www.teyme.es - e-mail: comercial@teyme.es

Suavizar aristas
 Cotas sin tolerancia según ISO2768-1 en grado m (medio)

Este plano es propiedad de TEYME Tecnología Agrícola, S.L. Prohibida su reproducción y cesión a terceros.

N	N_pieza	Denominación	Cant.	Proceso	Peso	N	N_pieza	Denominación	Cant.	Proceso	Peso
1	0270011008	CHAVETA DIN-6885 A 10x8x40	1	Compra Std	0.02	38	2400308016	KIT MANGUERAS ALIMENTACION GTA8 V6/7	1	Montaje	0.09
2	0500100840	T.LLO. DIN-933 8.8 Zn M8x40	4	Compra Std	0.0032	39	T020000014	C.JTO. DEFLECTORES INF. STU8	1	Montaje	2.67
3	0502500616	TORNILLO DIN-603 INOX M6x16	2	Compra Std	0.01	40	1140020030	C.JTO. REJA ASP. UNIC Ø800 C/DEFL - PIN	1	Soldadura	9.54
4	0520100800	TUERCA DIN-934 8.8 Zn M8	12	Compra Std	0.01	41	2400045239	C.JTO. TOBERA GTU8E Ø820x350 - PIN	1	Soldadura	22.27
5	0520101200	TUERCA HEX. DIN-934 M12 ZN	1	Compra Std	0.02						
6	0521100800	TUERCA D-985 AUTOBL. Zn M8	10	Compra Std	0.005						
7	0521101200	TUERCA D-985 AUTOBL. Zn M12	2	Compra Std	0.02						
8	0521101800	TUERCA D-985 AUTOBL. Zn M18	3	Compra Std	0.05						
9	0521102200	TUERCA HEX. DIN-985 M24 ZN	1	Compra Std	0.12						
10	0522100800	TUERCA D-1587 NIQUEL. M8	6	Compra Std	0.01						
11	0522110018	TUERCA CIEGA DIN 1587 M18 LATON	3	Compra Std	0.09						
12	0550100012	ARANDELA PLANA D-125 Zn Ø12	2	Compra Std	0.01						
13	0550100018	ARANDELA PLANA D-125 Zn Ø18	3	Compra Std	0.00						
14	0550100024	ARAND. PLANA DIN-125 M24	1	Compra Std	0.03						
15	0550120008	ARANDELA D-125 INOX D.8	32	Compra Std	0.27						
16	0550150008	ARANDELA D-9021 Zn Ø8	4	Compra Std	0.01						
17	0650010640	PASADOR ELAST. DIN-1481 D.6x40	1	Compra Std	0.00						
18	1160020122	MULTIPLICADOR SUSP. DV3600 2 VEL 1:3.5 - 1:4.2 H	1	Compra Std	186.20						
19	2331000002	POMO PALANCA REGULADORA	1	Compra Std	0.06						
20	2331000242	TAPA BUJE HELICE DEFLECTOR	1	Compra Std	0.13						
21	1140020028	REJA SALIDA Ø810	1	Compra c/plano	2.48						
22	1202000108	CRUCETA CARDAN CAMB. MARCHA GTA8 GTA7 - Zn	1	Compra c/plano	0.19						
23	2250140024	PALANCA CAMBIO MULT. G.A. i - STAR Ø900 - Zn	1	Compra c/plano	0.67						
24	2250200027	ARANDELA CONICA Ø20xØ28 GTL8	8	Compra c/plano	0.00						
25	2250250058	EJE GRUPO AIRE GTU8E Zn	3	Compra c/plano	1.05						
26	2331000277	CONO TURBO GTU8/E - 9E MEC	1	Compra c/plano	3.54						
27	2390010014	CASQUILLO GUIA EJES	12	Compra c/plano	0.02						
28	T020800001	CASQUILLO SUPL. EJE MULT. PAL. LDN - Zn	1	Compra c/plano	0.17						
29	T020900003	CONJUNTO HELICE Ø800 8A PL MOD. LDN	1	Compra c/plano	5.18						
30	3000200800	VARILLA ROSCADA DIN-975 INOX A2 M8	6	Corfe Teyme	0.03						
31	2000400497	SOPORTE DESMONTABLE PALANCA GTA8 Zn	1	Laser	0.06						
32	2000500338	CHAPA PRINCIPAL GTA8/9 STU9 - Zn	1	Laser	35.02						
33	2030200088	TAPA EMBELLECEDOR HELICE 7 P TEY. PLAS.	1	Laser	0.69						
34	T020300023	DEFLECTOR INF. DEL INOX STU8	1	Laser	1.30						
35	2400045544	SCJTO. ARCO INOX ZDA G-AIRE GTU8	1	Montaje	0.78						
36	2400045545	SCJTO. ARCO INOX DCHA G-AIRE GTU8	1	Montaje	0.83						
37	2400045610	KIT LLENADO ACEITE	1	Montaje sin tubo	0.28						

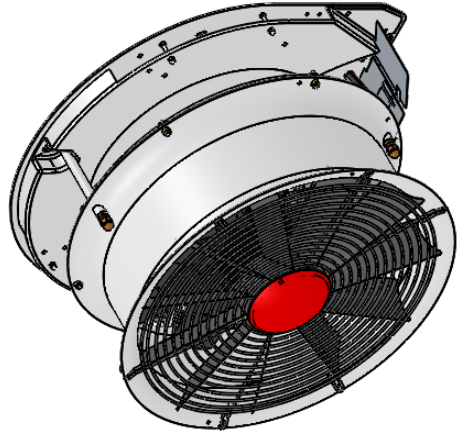
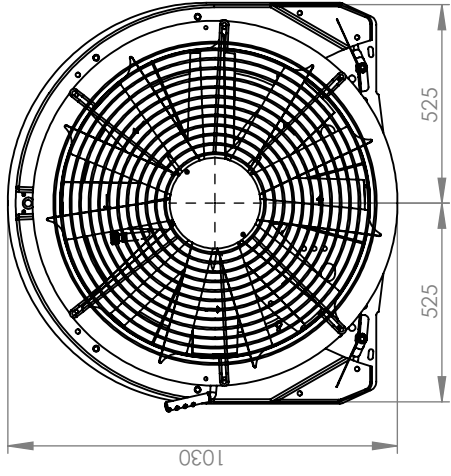
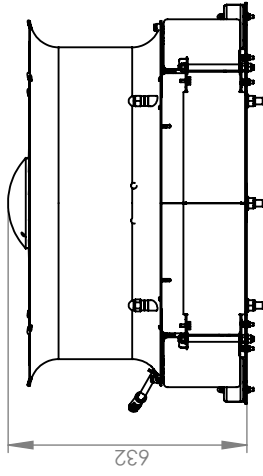

VISTA ISOMÉTRICA

Denominación: CJTO GTA8 LDN	Nº hoja: 3/3
Materia: Ø800	Peso: 90.84kg
Dibujado 16/03/2018	M. Amorós
Modificado	Interviene en:
GRUPOS DE AIRE	
Nº Plano	ESCALA
T020000004	1:25
Proceso	Versión
Montaje	00



Pol. Ind. SAU 3, C/ Girona - 25131 TORRESERONA (Lleida) - SPAIN
 Telf. 973 750 033 - Fax. 973 751 581
 www.teyme.es - e-mail: comercial@teyme.es

Suavizar aristas
 según ISO2768-1 en grado m (medio)

Este plano es propiedad de TEYME Tecnología Agrícola, S.L. Prohibida su reproducción y cesión a terceros.

32" FAN

Nº	CODE	DESCRIPTION
1	0270021108	DIN-6885 A 10x8x40 COTTER
2	0500100840	DIN-933 8.8 Zn M8x40 SCREW
3	0502500616	DIN-603 INOX M6x16 SCREW
4	0520100800	DIN-934 8.8 Zn M8 NUT
5	0520101200	DIN-934 M12 ZN NUT
6	0521100800	D-985 AUTOBL. Zn M8 NUT
7	0521101200	D-985 AUTOBL. Zn M12 NUT
8	0521101800	D-985 AUTOBL. Zn M18 NUT
9	0521102200	DIN-985 M24 ZN NUT
10	0522100800	D-1587 NIQUEL. M8 NUT
11	0522110018	DIN 1587 M18 BRASS NUT
12	0550100008	D-125 Zn Ø8 FLAT WASHER
13	0550100018	DIN-125 Ø18 FLAT WASHER
14	0550100024	D-125 Zn Ø24 FLAT WASHER
15	0550120008	D-125 Zn Ø8 INOX FLAT WASHER
16	0550150008	DIN-9021 Ø8 FLAT WASHER
17	0650010640	DIN-1481 D.6x40 LOCKING PIN
18	1160020122	DV3600 2SP+NP GEARBOX
19	2331000002	SHIFT LEVER KNOB
20	2331000242	SUCTION GRID HUB CAP
21	1140020028	32' EXIT GRID
22	1202000108	SHIFT LEVER CROSSHEAD
23	2250160024	GTA8 SHIFT LEVER
24	2250200027	BRASS CONICAL SLEEVE
25	2250250058	GTA8 SPACER SHAFT
26	2331000277	GTA8 SHIFT LEVER
27	2390010014	GTA8 GUIDE SLEEVE
28	T020800001	PROPELLER SLEEVE
29	T020900003	32" PROPELLER
30	3000200800	DIN-975 INOX A2 M8 THREADED ROD
31	2000400497	SHIFT LEVER HOLDER
32	2000500338	PRINCIPAL PLATE
33	2030200088	PROPELLER TRIM CAP
34	T020300023	GTA8 LOWER BLOWER HOUSING DEFLECTOR
35	2400045544	GTA8 LEFT NOZZLE HOLDER ARCH
36	2400045545	GTA8 RIGHT NOZZLE HOLDER ARCH
37	2400045610	OIL FILLING HOSE KIT
38	2400308016	FEEDING HOSE KIT
39	T020000014	GTA8 LOWER DEFLECTORS KIT
40	1140020030	GTA8 SUCTION GRID
41	2400045239	GTA8 BLOWER HOUSING